

# 炭素鋼

## ハーフカップリング

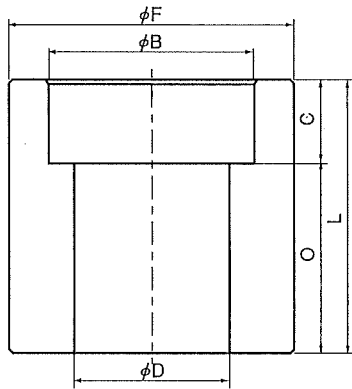

SW HC

単位:mm

## ボス

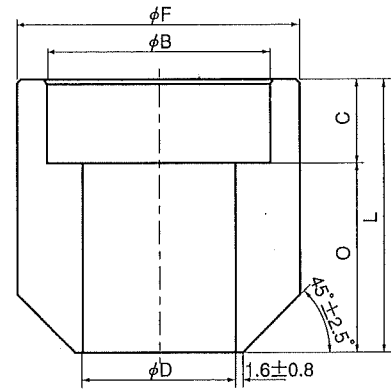

SW BOSS

単位:mm

呼称	記号	B	F	C	D		O	L
					1 欄	2 欄		
A	B	Sch 80						
8A	1/4	14.3	22.0	10.0	9.4	7.8	15.9	25.9
10A	3/8	17.8	27.0	13.0	12.7	10.9	17.5	30.5
15A	1/2	22.2	32.0	13.0	16.1	14.3	22.2	35.2
20A	3/4	27.7	38.0	15.0	21.4	19.4	23.8	38.8
25A	1	34.5	46.0	16.0	27.2	25.0	28.6	44.6
32A	1 1/4	43.2	57.0	18.0	35.5	32.9	30.2	48.2
40A	1 1/2	49.1	63.0	19.0	41.2	38.4	31.8	50.8
50A	2	61.1	75.0	22.0	52.7	49.5	41.3	63.3
65A	2 1/2	77.1	95.0	26.0	65.9	62.3	42.9	68.9
80A	3	90.0	110.0	29.0	78.1	73.9	44.5	73.5
100A	4	115.4	138.0	35.0	102.3	97.1	47.5	82.5
A	B	Sch 160						
15A	1/2	22.2	35.0	14.0	12.3		22.2	36.2
20A	3/4	27.7	42.0	16.0	16.2		23.8	39.8
25A	1	34.5	52.0	18.0	21.2		28.6	46.6
32A	1 1/4	43.2	60.0	19.0	29.9		30.2	49.2
40A	1 1/2	49.1	70.0	22.0	34.4		31.8	53.8
50A	2	61.1	85.0	25.0	43.1		41.3	66.3
65A	2 1/2	77.1	105.0	28.0	57.3		42.9	70.9
80A	3	90.0	120.0	31.0	66.9		44.5	75.5
100A	4	115.4	146.0	35.0	87.3		47.5	82.5

# ステンレス鋼

## ハーフカップリング

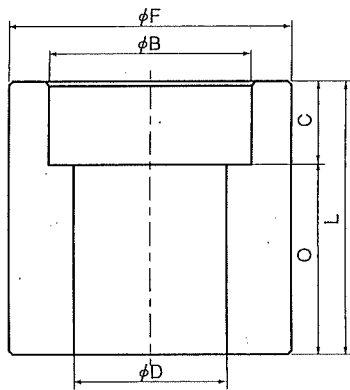

SW HC

単位:mm

## ボス

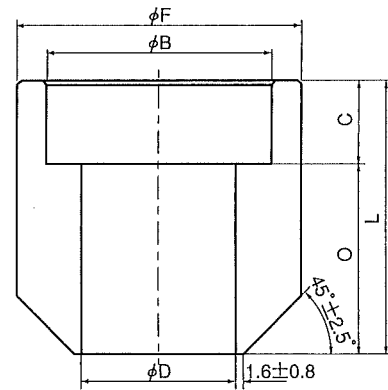

SW BOSS

単位:mm

呼称	記号	B	F	※C	D		O	L
					1欄	2欄		
A	B	Sch 80						
8A	1/4	14.3	22.0	9.6	9.4	7.8	15.9	25.5
10A	3/8	17.8	28.0	9.6	12.7	10.9	17.5	27.1
15A	1/2	22.2	32.0	9.6	16.1	14.3	22.2	31.8
20A	3/4	27.7	38.0	12.7	21.4	19.4	23.8	36.5
25A	1	34.5	46.0	12.7	27.2	25.0	28.6	41.3
32A	1 1/4	43.2	55.0	12.7	35.5	32.9	30.2	42.9
40A	1 1/2	49.1	65.0	12.7	41.2	38.4	31.8	44.5
50A	2	61.1	75.0	15.9	52.7	49.5	41.3	57.2
65A	2 1/2	77.1	95.0	15.9	65.9	62.3	42.9	58.8
80A	3	90.0	110.0	15.9	78.1	73.9	44.5	60.4
A	B	Sch 160						
15A	1/2	22.2	35.0	9.6	12.3		22.2	31.8
20A	3/4	27.7	42.0	12.7	16.2		23.8	36.5
25A	1	34.5	52.0	12.7	21.2		28.6	41.3
32A	1 1/4	43.2	60.0	12.7	29.9		30.2	42.9
40A	1 1/2	49.1	70.0	12.7	34.4		31.8	44.5
50A	2	61.1	85.0	15.9	43.1		41.3	57.2
65A	2 1/2	77.1	105.0	15.9	57.3		42.9	58.8
80A	3	90.0	120.0	15.9	66.9		44.5	60.4

注 ※Cは、最小寸法を示します。